

PRODUCT: 10,8V, industrial use lithium batteries

PROBATTERY CODE: 3ICPN₁/N₂/N₃-X & 3ICPN₁/N₂/N₃-2X

CLIENT: GENERIC INDUSTRIAL USE

Revision	Date	Person Responsible	Details
01	12/10/06	LC	Initial specification

Reference	Associated documents	Details

ING-001-F08-01 Page 1 of 10	Completed by: L. C. Quality Manager	Approved by: E.J.C Development Manager
--------------------------------	---	--

SUBJECT INDEX

1.- General

2.- Product Description

3.- Battery's electrical specification

- 3.1.- Nominal tension
- 3.2.- Capacity
- 3.3.- Impedance
- 3.4.- Operating environment
- 3.5.- Charging and discharging conditions
- 3.6.- Battery diagram

4.- Description of battery's components

- 4.1.- Cells
- 4.2.- Protection set
 - 4.2.1- Protection set's electrical circuit
 - 4.2.2.- Protection set's electrical specifications
 - 4.2.3.- Protection set's mechanical specifications
- 4.3.- **Intelligent measuring circuit (OPTIONAL)**
 - 4.3.1.- Measuring circuit's electronic specifications
 - 4.3.2.- Diagram of the intelligent version of the battery
 - 4.3.3.- Intelligent circuit's mechanical specifications
- 4.4.- Telemetry and access to the intelligent battery's parameters (OPTIONAL)
 - 4.4.1.- Communication Circuits with host controller
 - 4.4.2.- Diagram of battery with the communication system
 - 4.4.3.- Mechanical characteristics of the communication circuit

5.- Battery's mechanical structure

ING-001-F08-01 Page 2 of 10	Completed by: L. C. Quality Manager	Approved by: E.J.C Development Manager
--------------------------------	---	--

1.- General

This specification describes the Lith ion batteries from the 3ICPN₁/N₂/N₃-N₄ X y 3ICPN₁/N₂/N₃-2X series, intended for generic industrial use

N₁: Thickness of the cell used, stated in millimetres

N₂: Width of the cell used, stated in millimetres

N₃: Height of the cell used, stated in millimetres

X: The last identification letter of the pack depends on its geometric design.

2.- Product description

The battery is made up of four **rows** of series/parallel Lith ion prismatic cells, which have a variable capacity of between 100mAh & 1800mAh. In the case of the 2X models each row can be made up of 2 cells in parallel per **row** The standard pack comes equipped with the CPR-LI34-NG3 protection set.

3.- Battery's electrical specification

3.1.- Nominal Tension

Measurement after a discharge at I = 0,5C up to **D.O.D.** of 50%:

$$V_{\text{nominal}} = 10,8 \text{ V}$$

- Taking C as the pack's nominal capacity. This means that a discharge of a C= 1.8Ah pack at 0,5C implies a 0.9A current.
- D.O.D: Extent of discharge. This means to which percentage of the nominal capacity the battery has discharged.

3.2.- Capacity

Charging condition for measurement: I = 0,2C with a voltage of 12,75V until the charge current lowers 0.02C. Temperature 25°C (CCCV charge).

Charging conditions for measurement: I = 0,2C to a minimum voltage of 9V.

PACK CODE	C (Ah)	Cells per set
3ICPN ₁ /N ₂ /N ₃ -X	0,1 to 1,8	one
3ICPN ₁ /N ₂ /N ₃ -2X	1,8 to 3,6	two

ING-001-F08-01 Page 3 of 10	Completed by: L. C. Quality Manager	Approved by: E.J.C Development Manager
--------------------------------	---	--

Capacity dependency with temperature for cells charged at 25°C and discharged at the temperatures indicated in accordance with the aforementioned conditions.

Discharge temperatures				
	-10°C	0°C	25°C	60°C
Relative capacity	70%	90%	100%	95%

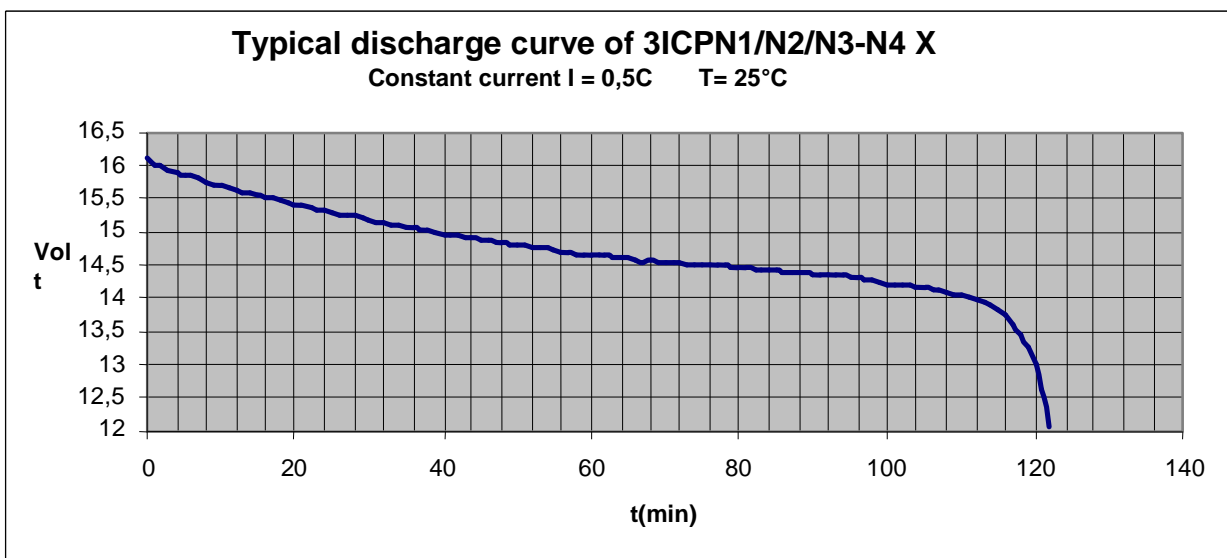

3.3.- Impedance

Measurement at 10,8V tension and at a frequency of 1kHz:

Z between 30 & 70 mΩ (each cell) in accordance to the cell being used

3.4.- Operating environment

Temperature and humidity limits within which the battery can be used:

Condition	Temperature min / max	Details
Charge	0°C to 45°C	
Discharge	-20°C to 60°C	
Storage	-20°C to 60°C	Less than 1 month
Storage	-20°C to 45°C	Less than 3 months
Storage	-20°C to 20°C	Less than 1 year

ING-001-F08-01 Page 4 of 10	Completed by: L. C. Quality Manager	Approved by: E.J.C Development Manager
--------------------------------	---	--

Note 1: In the storage conditions mentioned in the table above, the percentage of recoverable capacity of $C_{rec} > 80\%$ is guaranteed, on the understanding that C_{rec} :

C_{rec} = time after storage/initial discharge time

In all cases the relative operating environment humidity should be between 0 and 90% (without submerging the battery)

3.5.- Charging and discharging conditions

3.5.1.- Charge

The pack should be charged using a CC/CV (Constant current/Constant Volt). This means that during the first part of the charge the current should be limited to a value inferior to I_{Cmax} until the tension reaches a value at which the current reduces itself from I_{Cmax} . From this moment on the tension should be limited to a value inferior or equal to V_{Cmax} . The I_{Cmax} and V_{Cmax} values for the pack referred to in this specification are:

$$I_{Cmax} = 1C$$
$$V_{Cmax} = 12,8 V$$

3.5.2.- Discharge

The maximum discharge current for I_{Dmax} is:

$$I_{Dmax} = 1C \text{ continuous between } 0^{\circ}C \text{ \& } 50^{\circ}C$$

3.6.- Battery diagram

ING-001-F08-01 Page 5 of 10	Completed by: L. C. Quality Manager	Approved by: E.J.C Development Manager
--------------------------------	---	--

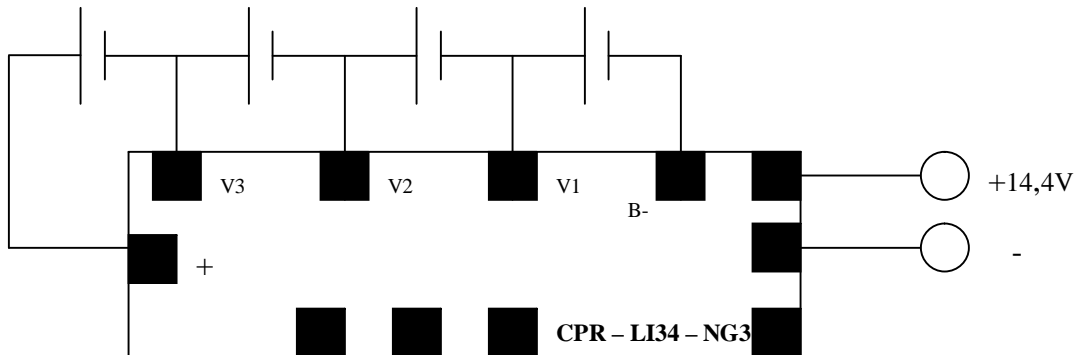

4.- Description of battery's components

4.1.- Cells

Below are the typical values of some of the prismatic cells used:

Parameter	Cell 043450	Cell 053048	Cell 103450
Nominal Tension	3,7V	3,7V	3,7V
Nominal Capacity	720mAh	650mAh	1800mAh
Tension at end of discharge	2,75V	2,7V	2,7V
Standard charge current	360mA	325mA	900mA
Maximum charge current	720mA	650mA	1800mA
Maximum discharge current	720mA continuous	650mA	1800mA
Internal resistance	< 60mΩ	<60mΩ	<90mΩ

4.2.- Protection set

4.2.1- Protection set's electrical circuit

The CPR-LI34-NG3 protection set is a monitoring and control circuit, which permits the measuring, and management of up to 4 Lith ion cells so that the charge and discharge parameters remain within the manufacturers specified values. At the same time, it controls the flow of current

ING-001-F08-01 Page 6 of 10	Completed by: L. C. Quality Manager	Approved by: E.J.C Development Manager
--------------------------------	---	--

through the system, differentiating peaks in demand from stable demand, and sets a protection threshold so as to avoid excesses in current, which could damage the circuit.

4.2.2.- Protection set's electrical specifications (@ 25°C)

4.2.2.1- Maximum electrical operating limits

- Maximum input voltage: Max 20VDC
- Maximum charge current: Max 7 A continuous
- Maximum discharge current: Max 7 A continuous

4.2.2.2 – Environmental conditions

- Operation: Temperature: -20°C to +70°C
Humidity: 0 to 90% (without submerging in water)
- Storage: Temperature: -40°C to +85°C
Humidity: 0 to 90% (without submerging in water)

4.2.2.3 – Circuit protector's operating limits

- Over voltage protection (OVP): 4,25V ± 0,025V
- Hysteresis voltage protection relay (HVPR): 200mV ± 50mV
- Over voltage protection delay (OVP): 1 sec
- Under-voltage protection (UVP): 2,4V ± 0,1V
- Under-voltage power recuperation (UVPR): 3V ± 80mV
- Response time of (UVPR): 100 msec
- Over current protection (OCP): adjustable in accordance with the cell being used
- Short-circuit relay delay: 10 msec

4.2.2.4 – Power consumption

- In operation: Maximum 5µA
- In cut mode: Maximum 1µA

4.2.3.- Protection set's mechanical specifications

ING-001-F08-01 Page 7 of 10	Completed by: L. C. Quality Manager	Approved by: E.J.C Development Manager
--------------------------------	---	--

A self-contained PCB with double layer fibreglass and epoxy resin, mounted using SMD technology. It is fixed to the pack using the metallic tabs used to solder the cells' electrodes. The size of the PCB is 55mm X 18mm.

4.3.- Intelligent measuring circuit (OPTIONAL)

4.3.1.- Measuring circuit's electronic specifications

The CSM-UN212-IG1 intelligent charge measuring set's main function is to precisely control the amp-hrs charge stored in the battery. To be able to do this it receives information from the protection board, which in turn allows it to identify the magnitude and direction of the circulating current. This information allows it to constantly calculate the effective charge stored by the battery. It also gives information about the system's operating temperature, the self-discharge suffered by cells during that time and the number of charge and discharge cycles that the battery has been subjected to. The information about the amount of charge stored by the battery is shown in percentage by 4 leds and an external check button. Pressing the button for five seconds will illuminate the leds, which in turn will indicate the percentage of charge stored. This percentage is not calculated by the pack tension, but by the effective amp-hrs calculated by the intelligent system. In the case of using an intelligent charger with SMBus, the battery will automatically report its characteristics upon being connected and will demand the appropriate charge and current it requires from the charger. On the contrary, the battery can be charged using any charger which meets the conditions specified in point 3.5.1

4.3.2.- Diagram of the intelligent version of the battery

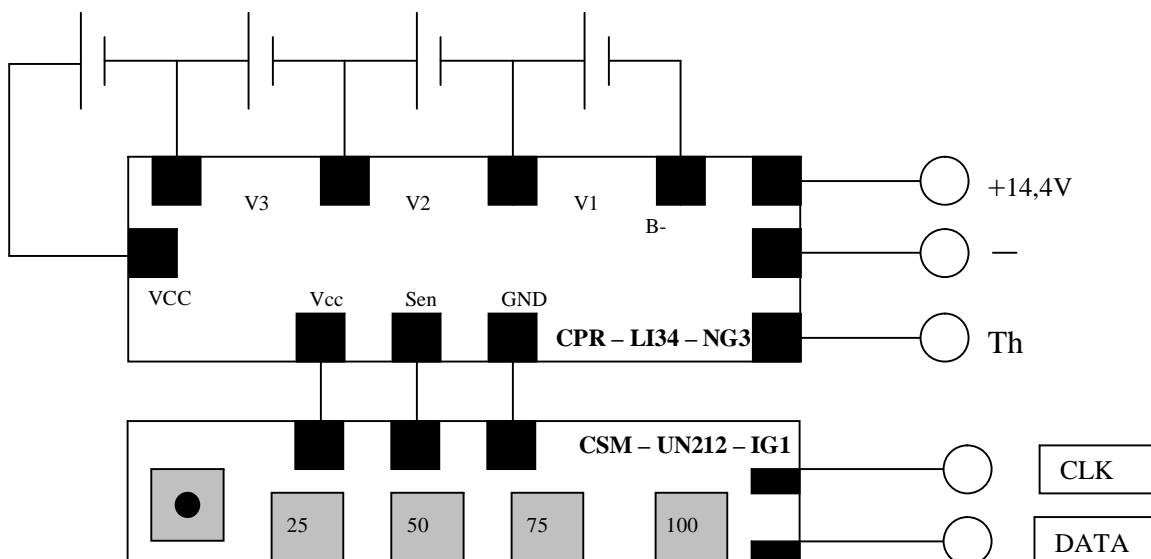

ING-001-F08-01 Page 8 of 10	Completed by: L. C. Quality Manager	Approved by: E.J.C Development Manager
--------------------------------	---	--

4.3.3.- Intelligent circuit's mechanical specifications

A self contained PCB, its dimensions are 65mm X 20mm. Made with double layer fibreglass and epoxy resin, mounted using SMD technology.

4.4- Telemetry and access to the intelligent battery's parameters (OPTIONAL)

4.4.1- External battery communication circuits

All the aforementioned parameters shown by the intelligent system can be accessed from a host controller through SMBus, RS232, RS485 or USB. The SMBus output is direct from the intelligent system, whereas the RS232 & RS485 outputs are implemented using the CCO-232485-IG1 communication accessory.

The following parameters are accessed:

- Capacity in mAh y en % with regard to the nominal
- Instant battery tension
- Instant charge and discharge current
- Average charge and discharge current
- Remaining charge or discharge time
- Quantity of charge-discharge cycles performed
- Continual adjustment of the battery's real capacity
- Battery model, serial number, and date of manufacture

Finally, the intelligent system keeps the battery's real capacity constantly updated, recalibrating itself each charge-discharge cycle.

4.4.2. Diagram of battery with the communication system

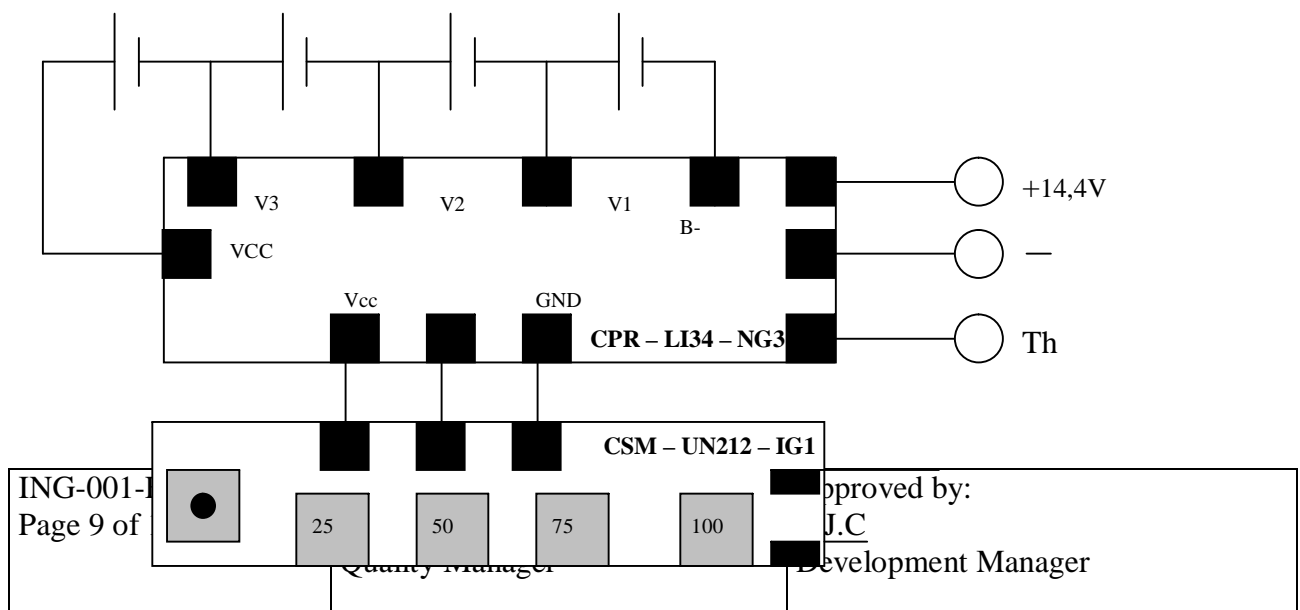

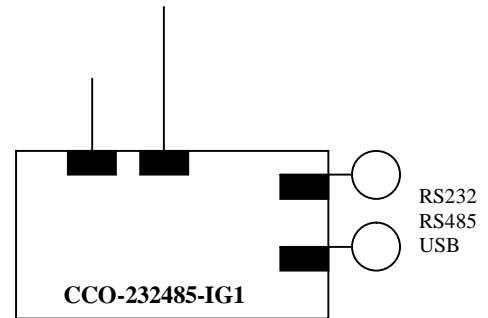

4.4.3.- Mechanical characteristics of the communication circuit

A self contained PCB, its dimensions are 65mm X 20mm. Made with double layer fibreglass and epoxy resin, mounted using SMD technology.

4.5.- Battery's mechanical structure

The battery pack as well as its control accessories, intelligence and communication, can come with a thermocontractil/shrink wrap cover or a plastic or metal cabinet, depending on the clients specifications.

<p>ING-001-F08-01 Page 10 of 10</p>	<p>Completed by: L. C. Quality Manager</p>	<p>Approved by: E.J.C Development Manager</p>
---	--	---